

# Improving Fatigue Strength of Welded Joints by Ultrasonic Impact Treatment

## Sougata ROY

Research Assistant  
ATLSS, Lehigh University  
Bethlehem, PA, USA

Sougata Roy, born 1966, received Master degree in Civil Engineering from Lehigh University in 2001. Currently he is a PhD candidate in civil engineering specializing in structural engineering.



## John W. FISHER

Professor Emeritus  
Lehigh University  
Bethlehem, PA, USA

John Fisher, born 1931, received PhD degree in Civil Engineering from Lehigh University in 1964. His research area encompasses fatigue behaviour of welded details and fracture analysis of steel structures.



## Summary

Enhancement in fatigue performance of welded joints by Ultrasonic Impact Treatment (UIT) was evaluated with large-scale rolled beam and built-up specimens having yield strength of 345 to 760 MPa. Eighteen rolled-beam specimens having welded details at cover plates and transverse stiffeners and eight built-up specimens having only transverse stiffener details were fatigue tested after treating the weld details by UIT. A partial factorial experiment design was carried out at various stress range levels between 52 and 201 MPa and at various levels of minimum stress, resulting in stress ratios not exceeding 0.6. Based on the test data fatigue design guidelines for AASHTO Category E' and Category C' details are proposed. UIT effectively elevated the fatigue limit without changing the slope of the S-N curve in the finite life region.

**Keywords:** fatigue design guidelines; fatigue life enhancement; fatigue limit; post-weld treatment; ultrasonic impact treatment; welded joint.

## 1. Introduction

Fatigue resistance of welded joints defined as a function of detail type and stress range in most of the current structural codes can be the serviceability limit state governing design of steel structures subjected to dynamic loading. Post-weld improvement of the fatigue resistance of common attachment details such as transverse stiffeners, cover plates, gusset plates, bulkheads and other transverse welded details that experience crack growth from a weld toe is therefore essential under certain design conditions for efficient use of modern high performance steels. In the AASHTO Specification [1] the fatigue resistance of these as-welded details are defined by Categories C', D, E or E'.

Over the past decade UIT has evolved as a promising technique for enhancement of fatigue strength of welded joints. The method involves post-weld deformation treatment of weld toe by impacts at ultrasonic frequency close to 27,000 Hz. The objective of the treatment is to introduce beneficial compressive residual stresses at the treated weld toe and to reduce stress concentration by improving the weld toe profile. The UIT equipment comprises a handheld tool and an electronic control box. The tool is easy to operate and provides an easy working condition with minimum noise and vibration. Compared to traditional "impact" treatment methods such as air hammer peening, shot peening and needle peening, UIT is claimed to be more efficient involving a complex effect of strain hardening, reduction in weld strain, relaxation in residual stress, reduction in operating stress concentration and thereby achieving a deeper cold worked metal layer [2-3]. Various investigators [4-6] demonstrated that the fatigue performance of welded joints, albeit in small size specimens, improved substantially following UIT.

A pilot study conducted at Lehigh University on three large-scale welded built-up girders made of High Performance Steel (HPS) Grade 70W and having yield stress of 485 MPa verified that fatigue performance of weld details such as stiffener and cover plates could be significantly improved by application of UIT [7]. These tests were conducted at stress ratio of minimum stress ( $S_{\min}$ ) to maximum

stress ( $S_{max}$ )  $R \leq 0.1$ . Only one of the treated stiffener details (Category C' [1] if untreated) developed a fatigue crack after achieving Category B fatigue resistance, which is the detail category for longitudinal web-flange weld [1]. Fatigue failure at as-welded details and from surface defects prevented obtaining data from other treated details.

Subsequently a research project was undertaken at Lehigh University in order to define the fatigue resistance of transverse welds at stiffeners and cover plate ends treated by UIT. The first part of the research program focused on rolled beam sections thereby eliminating the fatigue limit state at the web-flange junction [8]. This phase of tests yielded fatigue design guidelines for cover plate end welds only. In a follow up phase built-up girders fabricated from a new Cu-Ni HPS Gr100W developed at Lehigh University [9] were tested to establish conclusively the fatigue design guidelines for transverse stiffener welds.

## 2. Design of Experiments

### 2.1 Grade 50W Specimens

Eighteen W27x129 rolled wide flange beams with welded transverse stiffeners and cover plates and having minimum yield stress of 366 ~ 435 MPa were tested. Detail of the specimen is shown in Fig. 1. Transverse stiffeners were provided over the full depth of the girder welded to both the flanges and to the web. The weld details at the connections of transverse stiffener to the flange and web in flexural tension were considered critical for investigation. Three cover plate end weld configurations were investigated. These details were identified as: CP1 for cover plate detail having

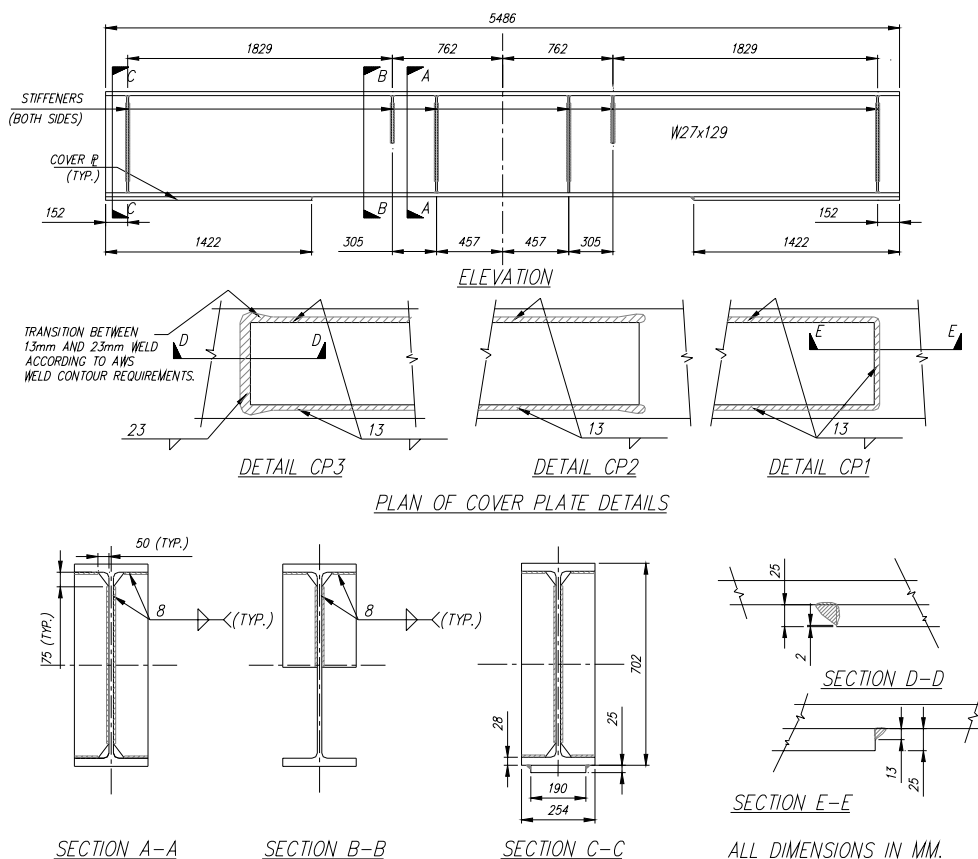

Fig. 1 Details of Gr50W Specimen

13 mm end weld ( $t = 0.5t_{cp}$ ,  $t$ : leg size of fillet weld,  $t_{cp}$ : thickness of cover plate), CP2 for cover plate detail that did not have any end weld and CP3 for cover plate detail with approximately 25 mm end weld ( $t = t_{cp}$ ). Details of CP1, CP2 and CP3 are shown in Fig. 1. All welds were fillet welds and all critical details were treated by UIT. Minimum stress and stress range ( $S_r$ ) were selected as the two control variables for all tests. A partial factorial experiment design was carried

out at two minimum stress levels and various stress range levels [8]. This led to several R-values 0.05~0.55 depending on the combination of  $S_{min}$  and  $S_r$ . After a few initial tests of cover plate details CP1 and CP2 it was evident that further investigation of these detail types would not provide any gainful results. Accordingly these details in the remaining specimens were modified to type CP3.

## 2.2 Grade 100W Specimens

Eight built-up girders with welded stiffeners were fabricated from HPS100W material having minimum yield stress of 725~760 MPa. Six of these specimens were 19 mm x 762 mm deep with 25 mm x 178 mm wide flanges. Details of this specimen are shown in Fig. 2. Other two specimens

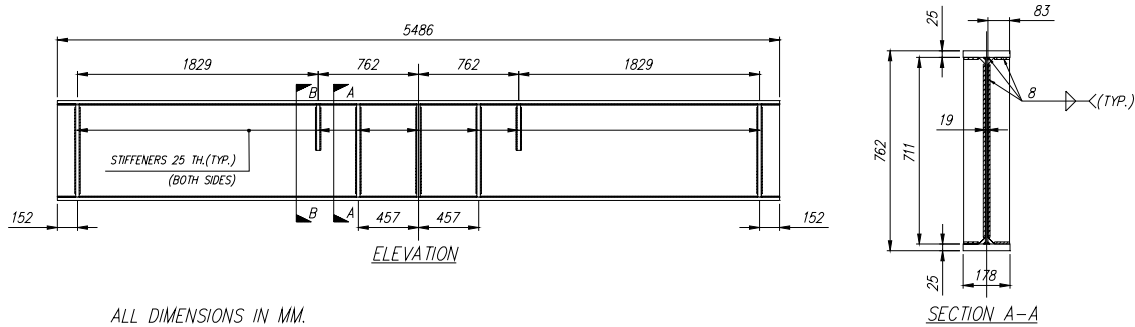

Fig. 2 Details of Gr100W Specimen

were 851 mm deep having 254 mm wide compression flange and 178 mm wide tension flange. Transverse stiffeners were provided over the full depth of the girder welded to both the flanges and to the web. The test matrix is shown in Table 1. Among all the fatigue tests that were conducted on the HPS70W and the Grade 50W specimens, only one stiffener detail developed fatigue crack from a weld fabrication defect at the toe.

Table 1 Test Matrix for Gr.100W Specimens

$S_{min}$ (MPa)	$S_r$ (MPa)			
	97	111	131	138
63			(R=0.32) HPS1 HPS2 HPS3	
97	(R=0.5) HPS6			
111		(R=0.5) HPS7 HPS8		
138		(R=0.56) HPS5 HPS6*	(R=0.5) HPS4	
166		(R=0.6) HPS3*		

The primary objective of this phase of the experimental program, therefore, was to determine the enhancement in fatigue limit of the transverse stiffener-flange welds treated by UIT and to establish the corresponding limiting value of R. Accordingly, a partial factorial experiment was carried out at four  $S_r$  and five  $S_{min}$  levels generating four different stress ratios R. The specimens that did not develop any detectable fatigue crack after being cycled beyond the 95% confidence limit for 95% survival life of longitudinal web-flange weld [10], were re-tested at an elevated  $S_{min}$ . In Table 1 these specimens are indicated by an asterisk (\*) suffixed to the specimen identifiers. It was assumed that the original combination of  $S_{min}$  and  $S_r$  was lower than the fatigue limit for the treated stiffener weld details and as such did not contribute to the fatigue damage

at the toe of the welds. Accordingly the results from the re-tests are presented as additional data points in the S-N plots.

### 3. Test Results

Grade 50W specimens failed by fatigue fracture of the tension flange at the end of one of the cover plate details. All the five specimens containing both CP1 and CP3 type details developed fatigue cracks at detail CP1. These cracks initiated at the weld toe except for one case where it started from a lack of fusion defect at root. The details type CP2 developed fatigue cracks at the termination of the longitudinal weld. All the fractured CP3 type details developed fatigue cracks at the toe. No fatigue cracks were detected in any of the stiffener details when the tests were discontinued. During metallographic studies after completion of the tests, however, fatigue cracks were detected in a couple of stiffener details that did not lead to fracture.

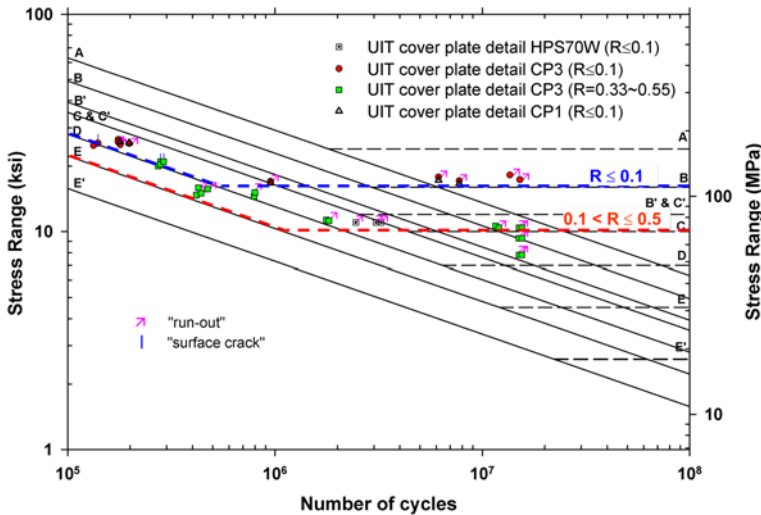

Fig. 3 S-N Curve for Cover Plate Details

the treated cover plate and stiffener details are plotted on the current AASHTO specified S-N curve as shown in Fig. 3 & 4. Data points corresponding to the details that did not develop detectable fatigue cracks at the time of discontinuing the tests are indicated as “run-out”. Test results demonstrate that all the details treated by UIT achieved substantial enhancement in fatigue strength.

### 4. Discussion and Conclusions

#### 4.1 Discussion

Fig. 3 shows that all five CP1 details exceeded Category D resistance at low  $S_{min}$  corresponding to  $R \leq 0.1$  and in particular two of the details exceeded Category B resistance curve at a lower  $S_r$ . The CP3 details that were tested at lower  $S_{min}$  i.e., at  $R \leq 0.1$  and at low  $S_r$  did not develop any fatigue cracks. These “run-out” data suggest an elevation in fatigue limit exceeding that of Category B for this type of detail treated by UIT. At higher R, the enhancement in fatigue strength for CP3 details reduced progressively; test data followed the slope of Category D resistance curve and the fatigue limit of the treated details exceeded that of Category C. Increase in fatigue life for CP2 details was limited to one category only.

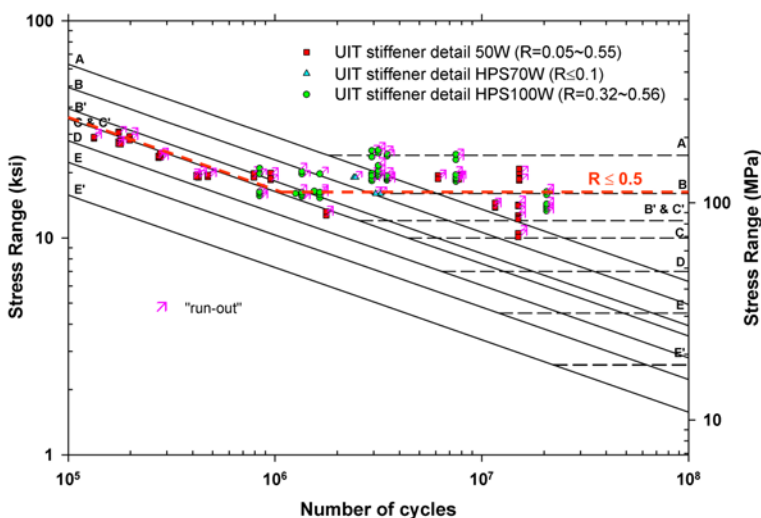

Fig. 4 S-N Curve for Stiffener Details

The specimens HPS1, 2, 4 & 7 developed fatigue cracks from weld porosity at the root of the longitudinal web-flange weld. These specimens were tested at  $R \leq 0.5$ . The specimens HPS3\*, 5 & 6\* developed fatigue cracks at the transverse stiffener weld. Two of these cracks initiated from lack of fusion defects at the root and the other developed at the toe. Specimens HPS3 & 6 did not develop any detectable fatigue cracks when cycled at  $R \leq 0.5$ . These tests were discontinued after  $7.5 \times 10^6$  and  $20 \times 10^6$  cycles respectively.

Fatigue life versus the average recorded nominal stress range data for the treated cover plate and stiffener details are plotted on the current AASHTO specified S-N curve as shown in Fig. 3 & 4. Data points corresponding to the details that did not develop detectable fatigue cracks at the time of discontinuing the tests are indicated as “run-out”. Test results demonstrate that all the details treated by UIT achieved substantial enhancement in fatigue strength.

In general fatigue crack at the treated cover plate end welds originated from

micro discontinuities at the weld toe [8]. In high fatigue life regime and particularly for smaller weld size, however, this failure mode may change to fatigue crack growth from weld root in the presence of a large weld discontinuity. This was evident from fatigue performance of CP1 and CP3 details. For optimum performance of UIT it is desirable to eliminate the possibility of fatigue crack growth from root discontinuities and to have fatigue crack growth only at the weld toe, where the beneficial effect of treatment delays or prevents the crack initiation and growth. Increasing the size of the cover plate end weld to the plate thickness reduces stress concentration [11] and therefore maximises the beneficial effect of the treatment.

Among all the test specimens only four treated stiffener details developed fatigue cracks, one in HPS70W specimen and three in HPS100W specimens. In Gr50W specimens test data on stiffeners were limited by failure of cover plate details. The “run-out” data points in *Fig. 4* corresponding to these specimens indicate substantial increase in fatigue resistance of treated stiffener details. In HPS100W specimens the fatigue cracks developed only when tested at  $R > 0.5$ . Nevertheless, all the fatigue fracture data points exceeded Category B fatigue resistance.

Enhancement in fatigue resistance of the treated details was dependent on both  $S_r$  and  $S_{min}$ . Previous research [11-14] on improvement of fatigue resistance by post-weld treatments indicated that increase in fatigue resistance of the treated details were sensitive to  $S_{min}$  (dead load effect) or  $R$ , in addition to  $S_r$ . Although substantial improvement was realized at low  $S_{min}$ , the beneficial effect of the treatment seemed to have virtually disappeared when subjected to high  $S_{min}$  after treatment. The magnitude of the stress ratio  $R$  is not absolute, however, and must be evaluated relative to the stress state during application of the post-weld treatment. Even at high values of  $S_{min}$  substantial enhancement could be achieved when the surface treatment was applied under sustained gravity load [14].

Design recommendation for enhancement in fatigue strength of welded details treated by UIT is indicated in *Fig. 3 & 4* by the dashed lines. In case of CP3 type cover plate end weld details having weld leg size equal to the thickness of the plate, for  $R \leq 0.1$  the fatigue strength may be increased to Category B in the infinite life region and to Category D in the finite life regime. For  $0.1 < R \leq 0.5$  the fatigue resistance may be increased to Category C and E for infinite and finite life regions respectively. In case of CP1 type cover plate end weld details with weld size equal to half the thickness of the plate, the fatigue strength may be increased to Category B in the infinite life region and to Category D in the finite life regime only for  $R \leq 0.1$ . This scenario is applicable for most of the cover plate end welds in service, where fatigue life may be enhanced by UIT provided it is ensured by non destructive evaluation that no fatigue crack has initiated at the weld toe. To avoid fatigue fracture due to cracks developing from root, however, these details should be inspected according to the inspection procedure for as-welded details. Fatigue strength of stiffener details may be increased to Category B in the infinite life region.

## 4.2 Conclusions

1. UIT was found to enhance the fatigue strength of treated transverse weld at cover plate and stiffener; this enhancement was more pronounced at lower  $S_{min}$  and at lower  $S_r$ , i.e., at low  $R$ .
2. Cover plate end weld details having weld size equal to the thickness of the cover plate performed better than the other type of cover plate details. It is recommended to use this type of

*Table 2 Recommendations for Enhancement in Design*

As-welded Detail Category	Enhanced Detail Category		
	Stress Ratio, $R$	Finite Life	Infinite Life
$E'$ ( $0.5t_{cp} \leq t \leq t_{cp}$ )	$R \leq 0.1$	D	B
$E'$ ( $t = t_{cp}$ )	$0.1 < R \leq 0.5$	E	C
$C'$	$R \leq 0.5$	$C'$	B

detail for all new construction. Enhancement in fatigue life for cover plate with no end weld is limited to one design category and it is recommended that this detail type not be used.

3. Fatigue strength of Category C' (transverse stiffener) and E' (cover plate end) weld details [1] may be enhanced according to *Table 2*

## Acknowledgements

This study was conducted at the Department of Civil and Environmental Engineering and at ATLSS Engineering Research Center, Lehigh University, Bethlehem, Pennsylvania, USA. The work was partially supported by the Federal Highway Administration (FHWA), the Pennsylvania Infrastructure Technology Alliance (PITA) and the American Iron and Steel Institute (AISI). Special acknowledgement is given to Applied Ultrasonics, Birmingham, Alabama, USA for providing the UIT equipment and application guidance. The authors will also like to thank Dr. Ben T. Yen and Dr. Eric Kaufmann for their valuable contribution to the project.

## References

- [1] AASHTO, *Standard Specification for Highway Bridges, 17th. ed.*, The American Association of State Highway and Transportation Officials (AASHTO), Washington D.C., 2002.
- [2] STATNIKOV E.S., TRUFYAKOV V.I., MIKHEEV P.P., and KUDRYAVTSEV YU. F., *Specification for Weld Toe Improvement by Ultrasonic Impact Treatment, IIW/IIS Doc. XIII-1617-96*, 1996.
- [3] STATNIKOV E.S., *Applications of Operational Ultrasonic Impact Treatment (UIT) Technologies in Production of Welded Joints, IIW/IIS Doc. XII-1667-97*, 1997.
- [4] STATNIKOV E.S., *Comparison of Post-weld Deformation Methods for Increase in Fatigue Strength of Welded Joints, IIW/IIS Doc. XIII-1668-97*, 1997.
- [5] HAAGENSEN P.J., STATNIKOV E.S., and LOPEZ-MARTINEZ L., *Introductory Fatigue Tests on Welded Joints in High Strength Steel and in Aluminium improved by various methods including Ultrasonic Impact Treatment (UIT), IIW Doc. XIII-1748-98*, 1998.
- [6] WRIGHT W., *Post-weld Treatment of a Welded Bridge Girder by Ultrasonic Hammer Peening*, Internal Research Report, Federal Highway Administration, Turner Fairbank Highway Research Center, USA, 1996.
- [7] TAKAMORI H., and FISHER J.W., "Tests of Large Girders Treated to Enhance Fatigue Strength", *Transportation Research Record*, Vol. 1, No. 1696, 2000, pp. 93-99.
- [8] ROY S., FISHER J.W., and YEN B.T., "Fatigue Resistance of Welded Details Enhanced by Ultrasonic Impact Treatment (UIT)", *International Journal of Fatigue*, Vol. 25, 2003, pp. 1239-1247.
- [9] GROSS J.H., and STOUT R.D., *Proposed Specification for an HPS 100W Cu-Ni Age-Hardening ASTM A709 Grade Bridge Steel, ATLSS Report No. 01-15*, ATLSS, Lehigh University, Bethlehem, PA, 2001.
- [10] KEATING P.B., and FISHER J.W., *Evaluation of Fatigue Tests and Design Criteria on Welded Details, NCHRP Report 286*, Transportation Research Board, Washington D.C., 1986.
- [11] GURNEY T.R., *Fatigue of Welded Structures*, Cambridge University Press, Cambridge, 1979.
- [12] MADDOX S.J., *Fatigue Strength of Welded Structures*, Abington Publishing, Cambridge, 1991.
- [13] SMITH I.F.C., and HIRT M.A., "A Review of Fatigue Strength Improvement Methods", *Canadian Journal of Civil Engineering*, Vol. 12, No. 1, 1985, pp. 166-183.
- [14] FISHER J.W., HAUSSAMMANN H., SULLIVAN M.D., and PENSE A.W., *Detection and Repair of Fatigue Damage in Welded Highway Bridges, NCHRP Report 206*, Transportation Research Board, Washington D.C., 1979.